

Features

- Ultra low quiescent current: 3.5 μ A (typ.)
- High input voltage (up to 12V)
- Output voltage:
1.8V, 2.5V, 2.7V, 3.0V, 3.3V, 3.5V, 5.0V
- Output voltage accuracy: tolerance \pm 3%
- Maximum output current: 250mA
- Low dropout voltage
- Low temperature coefficient
- TO-92, SOT-89 package

Applications

- Battery-powered equipment
- Voltage regulator for microprocessor
- Voltage regulator for LAN cards
- Wireless Communication equipment
- Audio/Video equipment

General Description

The TX3201_XX series is a set of three-terminal, low power, high voltage regulators implemented in CMOS technology. The series features extremely low quiescent current which is typically 3.5 μ A. They allow input voltages as high as 12V. The device provides large current with a significantly small dropout voltage.

The TX3201_XX consists of a high-precision voltage reference, an error correction circuit, and a current limited output driver. They are available with several fixed output voltages ranging from 1.8V to 5.0V. CMOS technology ensures low dropout voltage and low current consumption. Although designed primarily as fixed voltage regulators, these devices can be used with external components to generate variable voltages and currents.

Selection Table

Part No.	Output Voltage	Package	Marking
TX3201_18	1.8V	TO-92 SOT-89	TX3201_XX (for TO-92) TX3201_XX (for SOT-89)
TX3201_25	2.5V		
TX3201_27	2.7V		
TX3201_30	3.0V		
TX3201_33	3.3V		
TX3201_35	3.5V		
TX3201_50	5.0V		

Note: "XX" stands for output voltages.

For lead free devices, TO-92 package will add a "#" mark at the end of the date code, whereas SOT-89 package will add a "#" mark at the end of the marking.

Block Diagram

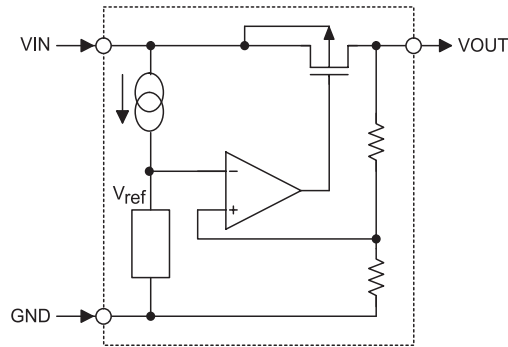

Pin Assignment

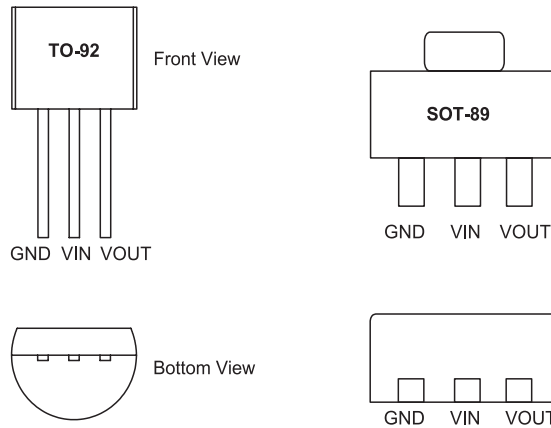

Absolute Maximum Ratings

Supply Voltage	$V_{SS}-0.3V$ to $V_{SS}+14V$	Storage Temperature	$-50^{\circ}C$ to $125^{\circ}C$
Power Consumption (*1)	500mW	Operating Temperature	$-40^{\circ}C$ to $85^{\circ}C$
Power Consumption (*2)	500mW		

Note: These are stress ratings only. Stresses exceeding the range specified under "Absolute Maximum Ratings" may cause substantial damage to the device. Functional operation of this device at other conditions beyond those listed in the specification is not implied and prolonged exposure to extreme conditions may affect device reliability.

*1: applied to TO-92
 *2: applied to SOT-89

Electrical Characteristics

TX3201_18, +1.8V Output Type

Ta=25°C

Symbol	Parameter	Test Conditions		Min.	Typ.	Max.	Unit
		V _{IN}	Conditions				
V _{OUT}	Output Voltage	2.8V	I _{OUT} =40mA	1.746	1.8	1.854	V
I _{OUT(MAX)}	Maximum Output Current	2.8V	V _{OUT} ≥1.62V	150	—	—	mA
ΔV _{OUT} *	Load Regulation	2.8V	1mA≤I _{OUT} ≤60mA	—	45	90	mV
V _{DROP**}	Dropout Voltage	—	I _{OUT} =40mA	—	170	—	mV
I _{SS}	Quiescent Current	2.8V	No load	—	3.5	7	μA
$\frac{\Delta V_{OUT}}{\Delta V_{IN} \times V_{OUT}}$	Line Regulation	—	I _{OUT} =40mA 2.8V≤V _{IN} ≤12V	—	0.2	0.3	%/V
V _{IN}	Input Voltage	—	—	—	—	12	V
$\frac{\Delta V_{OUT}}{\Delta T_a}$	Temperature Coefficient	2.8V	I _{OUT} =40mA -40°C<T _a <85°C	—	±0.7	—	mV/°C

TX3201_25, +2.5V Output Type

Ta=25°C

Symbol	Parameter	Test Conditions		Min.	Typ.	Max.	Unit
		V _{IN}	Conditions				
V _{OUT}	Output Voltage	3.5V	I _{OUT} =40mA	2.425	2.5	2.575	V
I _{OUT(MAX)}	Maximum Output Current	3.5V	V _{OUT} ≥2.25V	180	—	—	mA
ΔV _{OUT} *	Load Regulation	3.5V	1mA≤I _{OUT} ≤60mA	—	45	90	mV
V _{DROP**}	Dropout Voltage	—	I _{OUT} =40mA	—	110	—	mV
I _{SS}	Quiescent Current	3.5V	No load	—	3.5	7	μA
$\frac{\Delta V_{OUT}}{\Delta V_{IN} \times V_{OUT}}$	Line Regulation	—	I _{OUT} =40mA 3.5V≤V _{IN} ≤12V	—	0.2	0.3	%/V
V _{IN}	Input Voltage	—	—	—	—	12	V
$\frac{\Delta V_{OUT}}{\Delta T_a}$	Temperature Coefficient	3.5V	I _{OUT} =40mA -40°C<T _a <85°C	—	±0.7	—	mV/°C

TX3201_27, +2.7V Output Type

Ta=25°C

Symbol	Parameter	Test Conditions		Min.	Typ.	Max.	Unit
		V _{IN}	Conditions				
V _{OUT}	Output Voltage	3.7V	I _{OUT} =40mA	2.619	2.7	2.781	V
I _{OUT(MAX)}	Maximum Output Current	3.7V	V _{OUT} ≥2.43V	200	—	—	mA
ΔV _{OUT} *	Load Regulation	3.7V	1mA≤I _{OUT} ≤80mA	—	45	90	mV
V _{DROP**}	Dropout Voltage	—	I _{OUT} =40mA	—	100	—	mV
I _{SS}	Quiescent Current	3.7V	No load	—	3.5	7	μA
$\frac{\Delta V_{OUT}}{\Delta V_{IN} \times V_{OUT}}$	Line Regulation	—	I _{OUT} =40mA 3.7V≤V _{IN} ≤12V	—	0.2	0.3	%/V
V _{IN}	Input Voltage	—	—	—	—	12	V
$\frac{\Delta V_{OUT}}{\Delta T_a}$	Temperature Coefficient	3.7V	I _{OUT} =40mA -40°C<T _a <85°C	—	±0.7	—	mV/°C

TX3201_30, +3.0V Output Type

Ta=25°C

Symbol	Parameter	Test Conditions		Min.	Typ.	Max.	Unit
		V _{IN}	Conditions				
V _{OUT}	Output Voltage	4V	I _{OUT} =40mA	2.91	3	3.09	V
I _{OUT(MAX)}	Maximum Output Current	4V	V _{OUT} ≥2.7V	250	—	—	mA
ΔV _{OUT} *	Load Regulation	4V	1mA≤I _{OUT} ≤80mA	—	45	90	mV
V _{DROP} **	Dropout Voltage	—	I _{OUT} =40mA	—	95	—	mV
I _{SS}	Quiescent Current	4V	No load	—	3.5	7	μA
$\frac{\Delta V_{OUT}}{\Delta V_{IN} \times V_{OUT}}$	Line Regulation	—	I _{OUT} =40mA 4V≤V _{IN} ≤12V	—	0.2	0.3	%/V
V _{IN}	Input Voltage	—	—	—	—	12	V
$\frac{\Delta V_{OUT}}{\Delta T_a}$	Temperature Coefficient	4V	I _{OUT} =40mA -40°C<Ta<85°C	—	±0.7	—	mV/°C

TX3201_33, +3.3V Output Type

Ta=25°C

Symbol	Parameter	Test Conditions		Min.	Typ.	Max.	Unit
		V _{IN}	Conditions				
V _{OUT}	Output Voltage	4.3V	I _{OUT} =40mA	3.201	3.3	3.399	V
I _{OUT(MAX)}	Maximum Output Current	4.3V	V _{OUT} ≥2.97V	250	—	—	mA
ΔV _{OUT} *	Load Regulation	4.3V	1mA≤I _{OUT} ≤80mA	—	45	90	mV
V _{DROP} **	Dropout Voltage	—	I _{OUT} =40mA	—	90	—	mV
I _{SS}	Quiescent Current	4.3V	No load	—	3.5	7	μA
$\frac{\Delta V_{OUT}}{\Delta V_{IN} \times V_{OUT}}$	Line Regulation	—	I _{OUT} =40mA 4.3V≤V _{IN} ≤12V	—	0.2	0.3	%/V
V _{IN}	Input Voltage	—	—	—	—	12	V
$\frac{\Delta V_{OUT}}{\Delta T_a}$	Temperature Coefficient	4.3V	I _{OUT} =40mA -40°C<Ta<85°C	—	±0.7	—	mV/°C

TX3201_35, +3.5V Output Type

Ta=25°C

Symbol	Parameter	Test Conditions		Min.	Typ.	Max.	Unit
		V _{IN}	Conditions				
V _{OUT}	Output Voltage	4.5V	I _{OUT} =40mA	3.395	3.5	3.605	V
I _{OUT(MAX)}	Maximum Output Current	4.5V	V _{OUT} ≥3.15V	250	—	—	mA
ΔV _{OUT} *	Load Regulation	4.5V	1mA≤I _{OUT} ≤80mA	—	45	90	mV
V _{DROP} **	Dropout Voltage	—	I _{OUT} =40mA	—	80	—	mV
I _{SS}	Quiescent Current	4.5V	No load	—	3.5	7	μA
$\frac{\Delta V_{OUT}}{\Delta V_{IN} \times V_{OUT}}$	Line Regulation	—	I _{OUT} =40mA 4.5V≤V _{IN} ≤12V	—	0.2	0.3	%/V
V _{IN}	Input Voltage	—	—	—	—	12	V
$\frac{\Delta V_{OUT}}{\Delta T_a}$	Temperature Coefficient	4.5V	I _{OUT} =80mA -40°C<Ta<85°C	—	±0.7	—	mV/°C

TX3201_50, +5.0V Output Type

Ta=25°C

Symbol	Parameter	Test Conditions		Min.	Typ.	Max.	Unit
		V _{IN}	Conditions				
V _{OUT}	Output Voltage	6V	I _{OUT} =40mA	4.85	5	5.15	V
I _{OUT(MAX)}	Maximum Output Current	6V	V _{OUT} ≥4.5V	250	—	—	mA
ΔV _{OUT} *	Load Regulation	6V	1mA≤I _{OUT} ≤100mA	—	45	90	mV
V _{DROP} **	Dropout Voltage	—	I _{OUT} =40mA	—	60	—	mV
I _{SS}	Quiescent Current	6V	No load	—	3.5	7	μA
$\frac{\Delta V_{OUT}}{\Delta V_{IN} \times V_{OUT}}$	Line Regulation	—	I _{OUT} =40mA 6V≤V _{IN} ≤12V	—	0.2	0.3	%/V
V _{IN}	Input Voltage	—	—	—	—	12	V
$\frac{\Delta V_{OUT}}{\Delta T_a}$	Temperature Coefficient	6V	I _{OUT} =80mA -40°C<T _a <85°C	—	±0.7	—	mV/°C

Note: "*" Regulation is measured at constant junction temperature, using pulsed ON time.

"**" Dropout is measured at constant junction temperature, using pulsed ON time, and the criterion is V_{OUT} inside target value ±2%.

Application Circuits

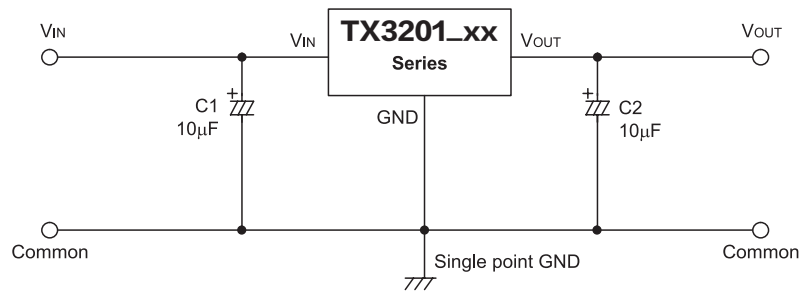

Package Information

T0-92 Outline Dimensions

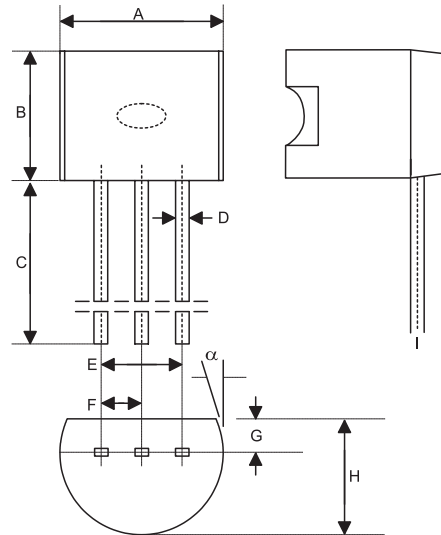

Symbol	Dimensions in mil		
	M in.	Nom .	Max.
A	170	—	200
B	170	—	200
C	500	—	—
D	11	—	20
E	90	—	110
F	45	—	55
G	45	—	65
H	130	—	160
I	8	—	18
α	4°	—	6°

SOT-89 Outline Dimensions

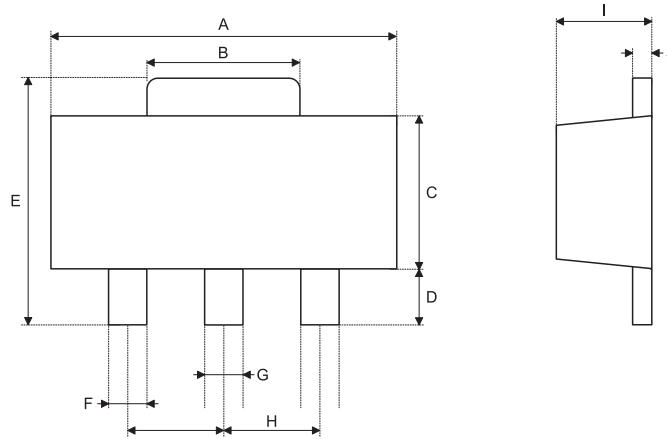

Symbol	Dimensions in mil		
	M in.	Nom .	Max.
A	173	—	181
B	64	—	72
C	90	—	102
D	35	—	47
E	155	—	167
F	14	—	19
G	17	—	22
H	—	59	—
I	55	—	63
J	14	—	17